

OPTIMIZATION OF INDUCTIVE RFID TECHNOLOGY FOR PRODUCT MANAGEMENT

Steve C. Q. Chen⁽¹⁾, Valerie Thomas⁽²⁾

⁽¹⁾Department of Electrical Engineering

⁽²⁾Center for Energy and Environmental Studies

Princeton University, Princeton, NJ 08544-5263

Abstract

Radio Frequency Identification (RFID) technology holds significant promise for managing products that contain hazardous materials. Passive RFID tags can be read at a distance and do not require a line of sight between the tag and the reader. This paper identifies the technical parameters that hurt RFID performance and evaluates measures to enhance performance. Issues addressed include optimal read range for the passive RFID tag, ways to increase the read range (i.e. increasing antenna size or raising the power of the RF field), and different algorithms for communication between the passive RFID tag and the reader. Also discussed are the process by which the tag modulates the carrier signal from the reader, the theory behind powering a passive tag via a LC circuit antenna, and the algorithm for simultaneously receiving and decoding information from more than one tag.

I. INTRODUCTION

The function of a passive Radio Frequency Identification System (RFID) can be described in its simplest form as that of a RFID reader identifying a RFID tag, reading data from the tag and, in some cases, writing data to the tag. The method in which this is done and the type of equipment used are both areas of ongoing research. The great appeal of RFID technology is that it allows information to be stored and read without requiring either contact or a line of sight between the tag and the reader. A RFID tag could be dirty, secretly hidden, or within an inaccessible space, and still be read by a reader. As better fabrication techniques are being developed, and as more advanced algorithms and circuit designs arise, the reliability and the read range of the passive RFID system continues to improve, and the cost of RFID systems continue to come down. Also, as the quality of RFID systems improves, the possible uses of passive RFID systems increase in number and in their impact on society and on our daily lives.

This paper covers the three areas of passive RFID systems. First, an explanation of how a passive RFID system works will be given. Then several examples will be presented that will give the reader an idea of the typical parameters of RFID systems available today. Next, the ways in which passive RFID systems are evolving and improving will be covered. Finally, the ways in which passive RFID systems are being used now and might be used in the future will be discussed.

Another type of RFID system involves the use of active tags as opposed to passive tags. Active tags contain on-board power sources that supply power for data transmission to the reader, whereas passive tags acquire their power solely from the carrier signal emitted by the RFID reader. Due to the complexity and cost of mounting a power source onto a tag, active tags are not practical for use with disposable consumer products. Therefore, this paper discusses only passive RFID systems, and from this point onward whenever RFID systems are mentioned it is in reference to passive RFID systems unless otherwise noted.

II. HOW A TYPICAL RFID SYSTEM PERFORMS ITS FUNCTIONS

The main components of a RFID system are the reader and tag. In a typical communication sequence between the reader and the tag, the following occurs:

- The reader emits a continuous radio frequency (RF) carrier sine wave.
- When a tag enters the RF field of the reader, the tag receives energy from the field.
- After the tag has received sufficient energy, it begins to modulate the carrier signal according to the data stored on the tag.
- This modulated carrier signal is resonated from the tag to the reader.

- The reader detects the modulated signal from the tag, and decodes signal in order to retrieve the data from the tag.
- Information is relayed to a host computer where more manipulation of the data may be performed, and where relevant information is finally displayed for the user.

In the above sequence of events, the reader and the tag both have their own roles to play. The job of the reader is to accomplish three tasks:

1. Provide energy for the tag,
2. Provide a carrier signal which the tag can modulate and resonate back to the reader,
3. Detect the modulated signal from the tag and decode it into useful information.

The job of the tag is to accomplish the following three tasks:

1. Utilize the energy provided by the reader,
2. Resonate the carrier signal sent out by the reader,
3. Modulate the resonated signal that is sent back to the reader.

The way in which the reader and tag accomplish their respective tasks will be the focus of the rest of this section.

A. The Functions of the Reader

1) *Provide energy for the tag*

During normal operation, the reader is able to power up the tag although there is no physical contact between the reader and the tag. The reader powers up the tag by emitting a RF field that is capable of generating power in the tag. The RF field is a time-varying electromagnetic field in the kHz or MHz range depending on the type of RFID system. When the tag feels the effect of this RF field, it is able to generate a DC voltage across its antenna coils. A time-varying magnetic field through a surface bounded by a closed loop induces a voltage around the loop. The small antenna in the RFID tag is such a loop.

The way that the reader generates this time-varying magnetic field is through its antenna, which is usually a roughly circular loop of wire. When current passes through a circular loop antenna, a magnetic field is generated perpendicular to the plane of the loop. The magnetic field induced by a current flowing through a circular loop is given by:

$$B = \frac{\mu_o INa^2}{2(a^2 + r^2)^{3/2}} \quad (1)$$

$$= \frac{\mu_o INa^2}{2r^3} \quad \text{for } r^2 \gg a^2 \quad (2)$$

where:

- μ_o = permeability of free space
- I = current through the loop
- N = number of turns in the loop
- a = radius of the loop
- r = perpendicular distance from the center of the loop

As can be seen from (2), the strength of the magnetic field is proportional to $1/r^3$. This is the major limiting factor in achieving longer read ranges in RFID systems, because the minimum B required to power up a tag becomes harder to maintain the farther the tag is removed from the reader antenna.

2) *Provide a carrier signal for the tag to modulate and resonate back to the reader*

The RF field emitted by the reader contains the carrier signal used by the tag to perform its functions. This carrier signal in typical high frequency RFID systems is around 13.56 MHz. The carrier signal serves both as a source of power to the tag and as the carrier signal for return data from the tag. Also, in tags that contain clocking circuitry, the carrier signal can act as a synchronized clock source.

3) *Detect the modulated signal from the tag and decode it into useful information*

The tag resonates the carrier signal sent from the reader. Not only does the tag resonate the carrier signal, but it also modulates the signal. This is discussed in section II.C. The group of signals that the tag returns to the reader is called backscatter modulation. Having received the backscatter modulation, the reader needs to decode the information. To do this, the reader must know the encoding scheme used by the tag. Among the many different encoding algorithms in use today, the most popular are the following [1]:

1. **NRZ (Non-Return to Zero) Direct:** '1' is represented by a logic high level. '0' is represented by a logic low level.
2. **Differential Biphase:** A level change occurs at middle of every bit clock period. '1' is represented by a change in level at

start of clock. '0' is represented by no change in level at start of clock.

3. **Biphase_L (Manchester):** Change occurs at middle of every bit clock period. '1' is represented by a high to low level change. '0' is represented by a low to high level change.

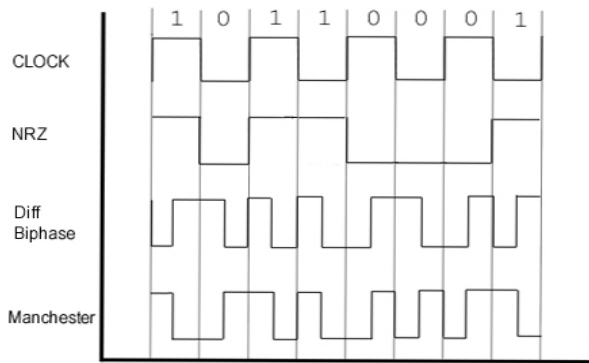

Fig. 1 Encoding Algorithms

In the microID 13.56 MHz RFID system by Microchip Technology Inc, Manchester encoding is used. Another factor to take into consideration in designing the reader is how the actual modulation of 1's and 0's are accomplished. The three types of modulation are listed below:

1. **Direct:** The amplitude-modulated signal is sent to the reader as it is, without any further modulation, the higher amplitude corresponding to a '1' and the lower amplitude corresponding to a '0.' This type of modulation accommodates high data rates, but is prone to error from noise [1].
2. **FSK (Frequency Shift Keying):** In FSK, '1' and '0' are distinguished by differences in frequency of the signal. The most common FSK mode represents a '1' with a frequency equal to the 1/8 the carrier frequency, and a '0' with a frequency equal to 1/10 the carrier frequency. The amplitude of the signal in this case is modulated so that half the duty cycle has a high voltage while the other half is low, and the reader detects changes in frequency (and hence distinguishes between 1 and 0) based on the changes in the length of the high/low duty cycles. This type of modulation results in a slower data rate, but provides excellent noise immunity [1].
3. **PSK (Phase Shift Keying):** In PSK, a change from a '1' to a '0' is accompanied by

a change in phase of the amplitude modulated signal. Two common types of PSK are: (1) change phase at any '0', and (2) change phase at any data change (0 to 1 or 1 to 0). PSK allows for a faster data rate than FSK while maintaining fairly good noise immunity [2].

B. Issues in Reader Design and Performance

The basic layout of a typical high frequency RFID reader is shown below in Fig. 2. The reader can be thought of as consisting of two sections: a transmitting section and a receiving section. The transmitting section contains the 13.56 MHz signal oscillator, the power amplifier, and the RF tuning circuits. The purpose of the tuning circuits is to match the impedance between the antenna coil circuit and the power amplifier at 13.56 MHz. The receiving section contains an envelope detector, hi-pass filters, and amplifiers.

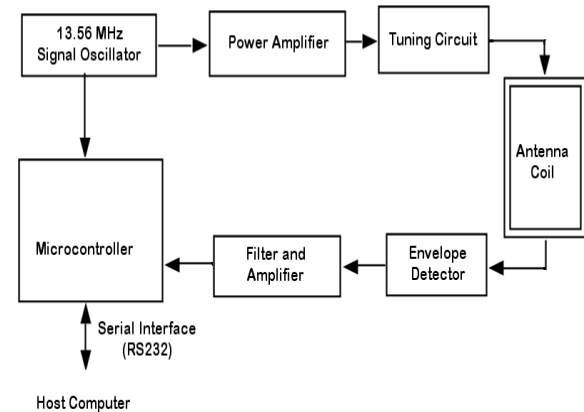

Fig. 2 Schematic Diagram of a high frequency RFID system [4]

When the tag is energized, it sends an amplitude modulated signal back to the reader. This signal causes a perturbation in the voltage amplitude across the antenna coil of the reader. The perturbations are detected by the envelope detector and passed to the filter and amplifier unit, which filters out the noise and amplifies the signal. This signal is then sent to the microcontroller, which does the data processing and outputs information to the host computer (usually via a serial interface such as a RS232 serial cable).

According to (2), a larger reader antenna means a larger B field and hence longer read range. Another way to achieve a larger read range is to increase the number of ampere-turns (NI). However, there are drawbacks to both options. Naturally, the larger the

antenna is, the less portable and more expensive the reader becomes. The consequence of increasing (NI) is a larger inductance in the reader antenna circuit that increases as the square of the number of turns. A high inductance load results in large amounts of reflected power (back EMF) as well as a large impedance that varies significantly as a function of frequency. Therefore, it is a good idea to keep (NI) as small as possible while achieving the minimum B field needed for the desired read range. An example of this is given in section III.B.

C. The Functions of the Tag

1) Utilize the energy provided by the reader

Passive RFID tags receive power for operation via an induced antennal coil voltage. This is similar to the process in a typical transformer whereby the primary coil transfers voltage to the secondary coil via inductive coupling [3]. In an RFID system, the reader antenna is the primary coil that transfers voltage to the tag antenna that acts as the secondary coil. The equations involved in this process are as follows:

The induced voltage in the tag antenna coil is defined as:

$$V = -N \frac{d\Phi}{dt} \quad (3)$$

where

- N = Number of turns in tag antenna coil
- Φ = Total magnetic flux through surface of tag antenna coil

The magnetic flux in (3) can be calculated as:

$$\Phi = \int \mathbf{B} \cdot d\mathbf{S} \quad (4)$$

where

- \mathbf{B} = Magnetic field; magnitude given in (1)
- \mathbf{S} = Surface area of the tag antenna coil

Note that Φ is defined as the integral of the dot product of the magnetic field \mathbf{B} generated by the reader antenna and the surface area \mathbf{S} of the tag antenna coil. Since the inner product of two vectors is maximized when the cosine angle α between the two vectors is 90 degrees, the maximum magnetic flux Φ flowing through the antenna coil is obtained when the reader antenna coil and the tag antenna coil are placed parallel to each other. This is one of the

conditions necessary for maximum read range in a typical RFID system.

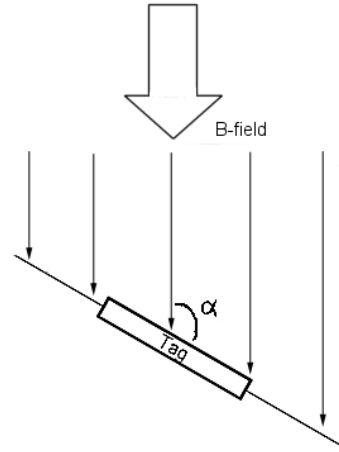

Fig. 3 Orientation of tag with respect to the direction of the magnetic field

Combining (1), (3), and (4), we have, after some mathematical manipulation, the following equation for the maximum induced voltage in the tag antenna coil:

$$\begin{aligned} V &= -\frac{\mu_o N_1 N_2 a^2 (\pi b^2)}{2(a^2 + r^2)^{3/2}} \frac{di}{dt} \\ &= -M \frac{di}{dt} \end{aligned} \quad (5)$$

where

- V = voltage in tag coil
- N_1 = number of turns in reader antenna coil
- N_2 = number of turns in tag antenna coil
- a = radius of reader coil
- b = radius of tag coil
- r = distance between the two coils
- i = current in reader coil
- M = mutual inductance between the tag and reader coils, given by:

$$M = \frac{\mu_o N_1 N_2 a^2 (\pi b^2)}{2(a^2 + r^2)^{3/2}} \quad (6)$$

The voltage calculated above is an AC voltage and needs to be converted to DC before the tag can turn on. This can be accomplished with a simple diode-capacitor circuit. Usually a high-voltage clamping diode is used in order to prevent excessive voltages from developing across the antenna wires [1].

2) *Resonate the carrier signal sent out by the reader*

When a capacitor and inductor are placed in parallel, such a circuit resonates at a frequency given by:

$$f_o = \frac{1}{2\pi\sqrt{LC}} \quad (7)$$

If the tag is receiving a signal from the reader with a frequency of 13.56 MHz, then the tag will be able to resonate the same signal back to the reader if the tag's antenna is tuned such that $[2\pi\sqrt{(LC)}]^{-1} = 13.56$ MHz. A sample layout of a tag antenna is shown in Fig. 4 below:

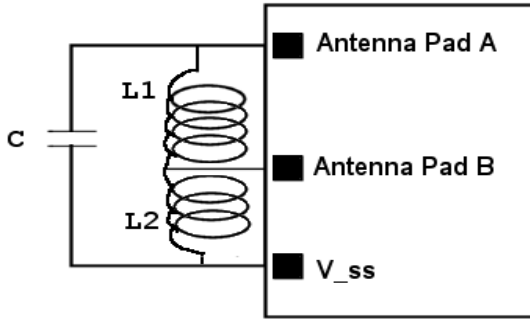

Fig. 4 Sample layout of a tag antenna [2]

In the above diagram, Antenna Pad A and Antenna Pad B are connected by a CMOS switch. When this switch is on, there is essentially a short between Antenna Pad A and Antenna Pad B, causing the total inductance seen in the antenna to be only L2. When the switch is turned off, the total inductance of the antenna is given by:

$$L_T = L_1 + L_2 + 2L_M \quad (8)$$

where:

- L_1 = Inductance of L1
- L_2 = Inductance of L2
- L_M = Mutual inductance between L1 and L2
= $K\sqrt{L_1L_2}$
- K = Coupling coefficient of L1 and L2
 $0 \leq K \leq 1$

This action of changing the total inductance in the antenna gives the tag the ability to modulated the signal being resonated back to the reader, as will be explained in the following section. V_{ss} is normally set to ground.

3) *Modulate the resonated signal that is sent back to the reader.*

Once the tag begins resonating the 13.56 MHz signal back to the reader, the reader antenna picks up the backscatter modulation and begins decoding the information from the tag. How the tag sends this information is the topic of this section. As discussed above, the tag is able to resonate the 13.56 MHz signal back to the reader because its antenna is tuned to that specific frequency. If the tag antenna is slightly out of tune with the 13.56 MHz reader, then the tag sends a weaker, lower voltage signal back to the reader [4].

If the tag antenna can achieve two states, a tuned state and a detuned state, then by alternating the state it is in, the antenna can send a variation of strong and weak signals to the reader. If the sequence of strong and weak signals correlates to data stored on the tag, then upon receiving the sequence of strong and weak signals from the tag antenna, the reader can decode the sequence and retrieve the data stored on the tag as long the signal is not corrupted by noise and the reader knows the modulation and encoding scheme of the tag.

The final problem is how the antenna switches between the two states, tuned and a detuned. This is solved by placing an internal modulation gate (CMOS) between V_{ss} and Antenna Pad B in Fig. 4. The choice of using CMOS as the gate comes from its zero quiescent current and good noise immunity [5]. The CMOS gate has a very low turn-on resistance (2-4 Ω) between drain and source [1]. Therefore, when the gate turns on (corresponding to a logic "high" period of the modulation signal), it acts like a short between Antenna Pad B and V_{ss} . The resonant frequency changes because the total inductance has changed. This is called a cloaking.

$$f_o = \frac{1}{2\pi\sqrt{L_2C}} \quad (9)$$

During a logic "low," the gate remains in an off state, and the total inductance remains the same L_T . Thus, the resonant frequency of the circuit remains at 13.56 MHz. This is called unclocking.

$$f_o = \frac{1}{2\pi\sqrt{(L_T)C}} \quad (10)$$

By cloaking and unclocking, the tag antenna sends an amplitude modulated signal to the reader which is then decoded and displayed on the computer or any other user interface. This cloaking/uncloaking

process is simply impedance switching caused by an active switch.

D. Anticollision Feature

An application may require the ability to read more than one RFID tag at the same time. For example, if more than one tag is brought into the RF field at the same time, and all are brought out of the RF field at the same time, then the only way for the reader to identify all the tags that entered the RF field is to read each tag while the other tags are also within its RF field. This is problematic because the same RF field will activate all the tags, and if all the tags start resonating the carrier signal back to the reader at the same time, there will be interference between the tags and the reader will get an incomprehensible jumble of signals [6].

One solution to the problem is to have each tag send data only during a specific window of time [1]. While a tag is not sending data, it is in sleep mode. After each tag has sent its data in its own window of time, then the first tag can wake up from sleep mode and send its data again, then the second, and so forth, resulting in a series of packets in time that together accommodate all the tags and individually do not overlap with any other packet in time. As an example, suppose that each tag has 256 bits to transmit at a baud rate of 100 kHz. Each tag will therefore take 2.56 ms to transmit its data packet. After transmission, each tag will go to sleep for, say, 100 ms, allowing for a theoretical number of 39 tags to send their data packets before the first tag sends its data packet again. This scheme is similar to the TDMA (Time Domain Multiple Access) scheme used in many wireless applications.

As the number of bits on each tag increases, it will take longer for each tag to transmit its data packet and therefore fewer tags will be able to be read within a certain time frame. This can be remedied by either increasing the time frame or increasing the baud rate at which the tag transmits its frequency. The later option is preferred since a smaller sleep time allows a more continuous flow of information between the tag and reader.

III. EXAMPLES OF CURRENT RFID PARAMETERS

A. Strength of Magnetic Field Required to Power up a Tag

The voltage induced across a tag antenna by an RF field from a reader is given by:

$$V = 2\pi f N S Q B_o \sin \alpha \quad (11)$$

where:

$$\begin{aligned} f &= \text{frequency of the arrival signal} \\ N &= \text{number of turns of coil in tag antenna loop} \\ S &= \text{area of the loop in square meters (m}^2\text{)} \\ Q &= \text{quality factor} \\ B_o &= \text{strength of the arrival signal} \\ \alpha &= \text{angle between the RF field vector and the tag plane (see Fig.3)} \end{aligned}$$

Suppose that the voltage required to turn on the tag is $4V_{pp}$ (V_{pp} , or “volts peak-to-peak,” refers to the total voltage amplitude of a sinusoid), and the tag begins to function when a DC voltage of $4/\sqrt{2}$ is developed across its antenna. Also, suppose that:

$$\begin{aligned} f &= 13.56 \text{ MHz} \\ N &= 4 \\ S &= 85.6 \times 54 \text{ mm (ISO standard 7810 card)} \\ Q &= 50 \\ \alpha &= 90^\circ \end{aligned}$$

Then from (11) the electromagnetic field required to operate the tag is,

$$\begin{aligned} B &= \frac{V_{DC}}{2\pi f N S Q \cos \alpha} \quad (12) \\ &= 4.49 \times 10^{-8} \cos \alpha \text{ (wbm}^{-2}\text{)} \end{aligned}$$

B. Number of Ampere-Turns Required to Produce Magnetic Fields of Various Strengths

The number of ampere-turns (NI) required for the reader antenna to produce a given magnetic field depends on the distance between the tag and the reader and also the radius of the reader antenna. From (1),

$$(NI) = \frac{2B(a^2 + r^2)^{3/2}}{\mu_o a^2} \quad (13)$$

(NI) can be calculated for different combinations of reader antenna radius a and read range r . Results for four hypothetical cases are shown in Table 1:

Table 1: (NI) required for different values of a and r

Case	a (cm)	r (cm)	NI (ampere-turns)
1)	10	30	0.226
2)	10	60	1.61
3)	20	60	0.452
4)	$60\sqrt{2}$	60	0.111

C. Optimal Radius of Reader Antenna to Achieve Minimum Number of Ampere-Turns

As explained in section II.B, it is good to keep the number of ampere-turns (NI) to a minimum. To find the optimal radius of the reader antenna to achieve the minimum value of (NI), we take the derivative of (13) with respect to the antenna radius a :

$$\begin{aligned} \frac{d}{da}(NI) &= \frac{2B}{\mu_o} \frac{d}{da} \frac{(a^2 + r^2)^{3/2}}{a^2} \\ &= \frac{2B}{\mu_o} \frac{(a^2 + r^2)^{1/2}(a^2 - 2r^2)}{a^3} \end{aligned} \quad (14)$$

The above equation is minimized when $a^2 = 2r^2$, or

$$a = \sqrt{2}r \quad (15)$$

In the example of section III.B, the relationship between a and r in case 4 corresponds to the above equation. However, as read range increases, an antenna size that holds to (15) will soon become impractically large. Therefore, a tradeoff must be made between keeping the number of ampere-turns small and keeping the size of the antenna small.

IV. WAYS TO IMPROVE FUNCTIONALITY AND PERFORMANCE IN RFID SYSTEMS

The read range of a typical RFID system is defined as the maximum communication distance between the reader and tag. The main obstacle in achieving a long read range (i.e. more than a couple feet) is the ability to power the tag via induction. The tag needs to be powered up before it can be read, and while the tag is communicating with the reader, the strength of the signal from the reader needs to be large enough so that the backscattered modulation from the tag can be picked up by the reader.

A. Frequency Band

In general, RFID systems operating in a higher frequency band have a longer read range than those operating in a lower frequency band. This is due to the fact that the strength of the voltage induced in the tag is directly related to the frequency of the electromagnetic field passing through the tag antenna as shown in (11), duplicated here for reference:

$$V = 2\pi fNSQB_o \sin \alpha \quad (11)$$

where:

- f = frequency of the arrival signal
- N = number of turns of coil in tag antenna loop
- S = area of the loop in square meters (m^2)
- Q = quality factor
- B_o = strength of the arrival signal
- α = angle between the RF field vector and the tag plane (see Fig.3)

B_o is defined in (1) and can be seen to vary with $1/r^3$. Thus, the induced voltage V varies with f/r^3 . As the read range of the tag increases, an increase in the frequency is required to maintain the minimum voltage required to turn on the tag, all other variable being held constant.

Currently, the highest frequency band under which commercially available RFID devices operate is around 13.56 MHz. The FCC limits for 13.56 MHz frequency bands are as follows:

1. Tolerance of the carrier frequency: 13.56 MHz +/- 0.01 % = +/- 1.356 kHz
2. Frequency bandwidth: +/- 7 kHz
3. Power level of fundamental frequency: 10 mV/m at 30 meters from the transmitter
4. Power level for harmonics: -50.45 dB down from the fundamental signal [7]

The tolerance of the carrier frequency depends mainly on the signal oscillator and should not be a problem as long as the parasitic capacitances and inductances of the reader circuit are not unusually large. The frequency bandwidth corresponds to the range in frequency where the signal does not drop below 3 dB of its peak amplitude; this can be regulated by a bandpass filter. The power level varies linearly with the current running through the reader antenna and should be measured by a field strength analyzer. It is the responsibility of the RFID system designer to stay within these FCC limits.

B. Size of Antenna

1. Reader Antenna

Another limitation on the read range of RFID systems is the size of the reader antenna. Although the size of the reader can be reduced by sacrificing a higher number of ampere-turns (NI) as described in section III.C, eventually the size of the antenna does limit the range of a RFID system. How large a diameter of the reader antenna coil is allowed will depend on the application.

2. Tag Antenna

The size of the tag antenna is also a factor in the length of the read range. As can be seen in (4) and (5), the larger the area of the tag antenna coil, the larger the magnetic flux through the tag antenna and, thus, the larger the voltage induced on the tag. One could also increase the number of turns in the tag antenna coil in order to achieve a larger read range. However, both options result in a more expensive and bulkier tag. Also, one must keep in mind possible effects of the parasitic capacitance that occurs as the number of turns in the coil increases [6].

C. Quality Factor

The quality factor Q is a measure of how well a resonant circuit retains energy. A higher Q means the circuit leaks very little energy, while a low Q means the circuit dissipates a lot of energy. The definition of Q can be written as:

$$Q = \frac{\text{Stored energy}}{\text{Energy loss per cycle}}$$

In Fig. 4, the entire tag circuitry can be thought of as a parallel RLC circuit, with R representing the entire ohmic losses of the tag. In this case, Q can be defined as:

$$Q = \omega_o RC \quad (16)$$

$$= \frac{R}{\omega_o L} \quad (17)$$

where ω_o is the resonant frequency of the circuit. For a parallel RLC circuit, ω_o equals $(LC)^{-1/2}$, which implies:

$$Q = R \sqrt{\frac{C}{L}} \quad (18)$$

However, Q can also be calculated by the following equation [3]:

$$Q = \frac{f_o}{B} \quad (19)$$

where:

$$\begin{aligned} f_o &= \omega_o / (2\pi) \\ B &= \text{bandwidth of the circuit} = (2\pi RC)^{-1} \end{aligned}$$

As can be seen from (11), the induced voltage on the tag antenna coil is directly proportional the quality

factor Q . Typical values of Q for a parallel RLC resonant circuit are around 40 [1].

D. Sensitivity of the Reader and Electrical Noise

In order for a RFID system to work, the reader must be able to detect the perturbations created across its antenna coil voltage by the backscattered radiation from the tag. The read range of an RFID system depends on the sensitivity of the reader to such signals, which in turn depends on the Q of the reader antenna coil as well as the strength of the signal coming from the tag and the orientation of the reader antenna with respect to the tag antenna (as described in Fig. 3).

Not only does the reader have to detect the backscattered modulation, it also has to successfully interpret the signals coming from the tag. Such signals are often affected by electrical noise coming from other electrical components nearby. The degree of immunity of the data signals to such noise depends heavily on the modulation and coding schemes used, which were described in section II.A.3.

E. Summary

In general, the read range of passive RFID systems is affected by the factors listed in Table 2:

Table 2: Factors Affecting RFID Read Range

1.	Operating frequency and performance of antenna coils
2.	Q of antenna and tuning circuit
3.	Antenna orientation
4.	Excitation current
5.	Sensitivity of receiver
6.	Coding (or modulation) and decoding (or demodulation) algorithm
7.	Number of data bits and detection (interpretation) algorithm
8.	Condition of operating environment (electrical noise, etc)

Conditions (1-3) are related to the antenna configuration and tuning circuit on the tag. Conditions (4-5) depend on the design of the reader circuit. Condition (6) is a communication protocol of the RFID system, and condition (7) is related to the software program that runs the RFID system. Condition (8) is generally unavoidable. However, the effects of noise can be reduced by placing a bandpass filter centered at the carrier frequency at the receiving

end of the reader, or by averaging in the case of white noise (noise that does not vary with frequency).

V. CURRENT AND FUTURE APPLICATIONS OF RFID SYSTEMS

A. Current Applications

Current applications of RFID systems include anti-shoplifting systems, personnel identification, entry access control in private areas, garment identification in the laundry industry, baggage checking in the airline industry, and personal pet identification [6]. Because of the dynamic evolution of RFID technology and the amazing versatility of RFID, there are likely to be many more RFID applications being currently developed.

B. Future Applications

The small read range of passive RFID devices limits their extension to new applications. Applications that require a long read range usually utilize active RFID systems where the tag contains an on-board power supply. One example of an active RFID application is automated highway toll collecting systems such as E-Z Pass. These systems are already in everyday use in the United States and many foreign countries. If a way were discovered to increase the read range of passive RFID devices to satisfy the requirements of applications that require a long read range, then the use of such long range passive RFID devices would become widespread, mainly due to the extremely cheap production costs of passive RFID devices.

One possible use of passive RFID devices is in the tracking of packages in the shipping industry. This can be done through either pre-programmed tags or programmable tags. Individual users would order pre-programmed tags for addresses that they commonly send to or for their return address. Individuals could store presets on their individual programmers so that they could quickly program a blank programmable tag for any address stored in their programmer. Having a RFID device on a package would allow the shipping industry to keep track of shipments more efficiently.

RFID could have numerous environmental applications. It could be used to enhance the

lifecycle management of products and waste management in general [8]. However, the technical limitations of inductive RFID will limit its potential applications. For example, use of passive RFID to identify items in a garbage truck would require a relatively large read-range. If such a read-range were achieved, the magnetic field required to power the passive RFID tag might be in violation of FCC limits.

However, shorter range applications, such as the monitoring of items going in to trash cans or recycling bins, are well suited to RFID technology. For example, special containers (recycling bins) could be set up to record each time an item is deposited, and the owner could be rewarded through electronic credit to his account. As homes and businesses become more integrated into the Internet, RFID tags have the potential to enhance asset and waste management.

REFERENCES

- [1] *MicroID 13.56 MHz RFID System Design Guide*. Chandler: Microchip Technology Inc., 1999.
- [2] Siebert, William. *Circuits, Signals, and Systems*. 1986. Cambridge: The MIT Press; New York: McGraw-Hill, 1998.
- [3] Sedra, Adel, and Kenneth Smith. *Microelectronic Circuits*. New York: Oxford University Press, 1998.
- [4] Streetman, Ben G. *Solid State Electronic Devices*. Upper Saddle River: Prentice-Hall, 1995.
- [5] Horowitz, Paul, and Winfield Hill. *The Art of Electronics*. Cambridge: Cambridge University Press, 1989.
- [6] Fletcher, Richard R. *A Low-Cost Electromagnetic Tagging Technology for Wireless Identification, Sensing, and Tracking of Objects*. Massachusetts: Massachusetts Institute of Technology, 1997.
- [7] Federal Communications Commission. *Radio Frequency Devices*. 1999. http://www.fcc.gov/Bureaus/Engineering_Technology/Documents/cfr/1998/47cfr15.pdf.
- [8] Thomas, V., W. Neckel and S. Wagner, "Information Technology and Product Lifecycle Management," Proc. IEEE Int'l. Symp. Electronics and Environment 1999, pp. 54-57.